

**COMPETITOR SERIES®**

**C-2RB-35-HC**

**C-2FB-35-HC**

# SPACE SAVING TWO DOOR REACH-INS

- Beautiful ergonomic construction & rounded corners
- Digital temperature controller & read-out
- All stainless steel exterior and interior
- Forced air refrigeration system
- Recessed door handles
- LED Interior Lighting
- Door locks
- 90 degree hold open door feature for loading products
- Migali® Protection Plan: 2 Year Parts & Labor Warranty, 5 Years Compressor Warranty
- Bottom mount compressor for enhanced efficiency
- Pre-installed casters and shelving
- Auto-defrost
- Air plenum across back wall for even temperature distribution throughout cabinet interior
- All Natural R290 Hydrocarbon Refrigerant
- US Department of Energy Certified
- Air Pressure Relief Valve for ease of opening doors

MODEL	DOORS	CAPACITY CU/FT	SHELVES	H/P	AMPS	VOLTAGE	ENERGY CONSUMPTION KWH/24 HR	PLUG TYPE	EXTERIOR DIMENSIONS W X D X H*	INTERIOR DIMENSIONS W X D X H	PACKAGED DIMENSIONS W X D X H	WEIGHT	PACKAGED WEIGHT
C-2RB-35-HC	2	35	6	1/5	3.2	115/60/1	2.55	Nema 5-15P	39.5 x 31.5 x 83.1	34.75 x 26.1 x 60	41 x 33 x 85.8	317 lbs.	362 lbs.
C-2FB-35-HC	2	35	6	3/4+	8.6	115/60/1	7.56	Nema 5-15P	39.5 x 31.5 x 83.1	34.75 x 26.1 x 60	41 x 33 x 85.8	331 lbs.	375 lbs.

\* Total height includes casters

**FOR COMMERCIAL USE ONLY**

NOTE: MIGALI® RESERVES THE RIGHT TO CHANGE SPECIFICATIONS WITHOUT NOTICE



TOLL FREE: 800.852.5292  
WEB: www.migali.com



# DIMENSIONAL DRAWINGS

C-2RB-35-HC & C-2FB-35-HC

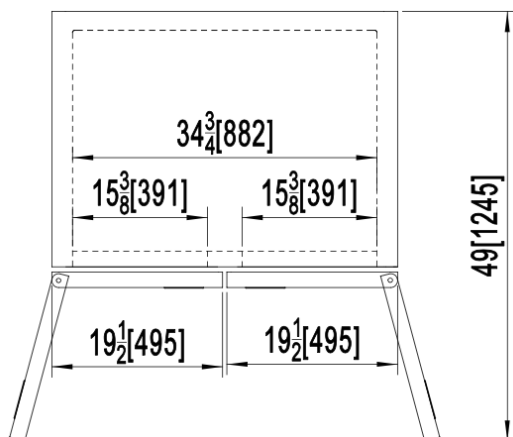
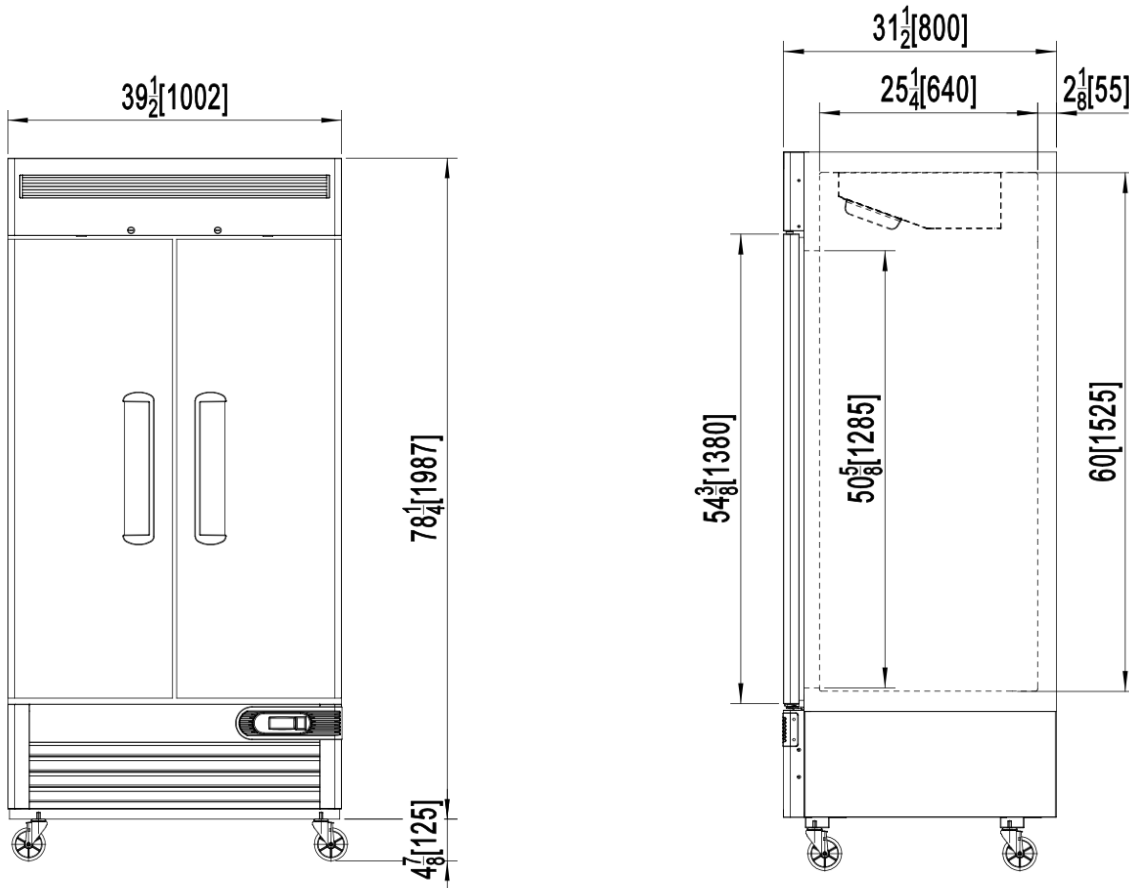

MIGALI® REMAINS AN AMERICAN FAMILY COMPANY SINCE 1955