

Gas Restaurant Ranges with Oven

24" WIDE



All Stainless-Steel construction, interior and exterior front, and sides. To include **Stainless-Steel grate supports, burner support and pilot tubing**. The all Stainless-Steel construction is designed to last and perform in the most demanding kitchens.

Heavy gauge welded frame on 6" adjustable legs, Stainless-Steel back riser durable enough to hold your broiler without any additional supports. Comes standard with Stainless-Steel cantilever shelf with an optional extended shelf for broiler mounting.

For the safety and convenience of operators, our Asber ranges come standard with a 5" Stainless Steel bull nose landing ledge, Zamac heat resistant knobs for added durability, and reinforced valve system for extra safety.

All units are ETL certified under ANSI Z83.11-CSA 1.8 standard.

OPEN BURNER:

- **30.000 BTU** cast iron lift off burners.
- Heavy Duty 12" x 12" cast iron top grates and pilot protection.
- Independent pilot per burner.
- Stainless Steel drip tray.

GRIDDLES:

- Stainless Steel perimeter top.
- Cold-rolled steel plate 3/4" thick welded to the perimeter top of the truss.
- 4" grease trough channel.

OVEN:

- Stainless Steel interior with porcelain back door and bottom.
- Removable Stainless-Steel door for easy cleaning.
- Oversized durable Stainless-Steel door handle.
- Thermostatic controlled from 250 °F to 550 °F.
- Electronic spark ignition.
- Standard with (1) stainless steel oven rack.
- **Accepts full size sheet pans (18" x 26")**.



AER-4-24



AER-G24-24-H

OPTIONS & ACCESSORIES

5" castors.

Additional racks for oven.

Extended overshell for Salamander / Cheesemelter.

Specify LPG or Nat. Gas (comes standard with conversion kits).

Specify is above 2000 ft. elevation.

MODEL	TOTAL BTU PER HOUR	DIMENSIONS			SHIPPING WEIGHT (lbs)
		Width	Depth	Height	
AER-4-24	150.000	24"	33 1/2"	56 3/8"	335
AER-G24-24-H	78.000	24"	33 1/2"	56 3/8"	335

1. Height includes 6" legs and backsplash. 2. Specifications are subject to change without prior notice.

Gas Restaurant Ranges with Oven

24" WIDE



AER-4-24 TOP AER-4-24 FRONT AER-4-24 SIDE AER-G24-24-H TOP AER-G24-24-H FRONT AER-G24-24-H SIDE

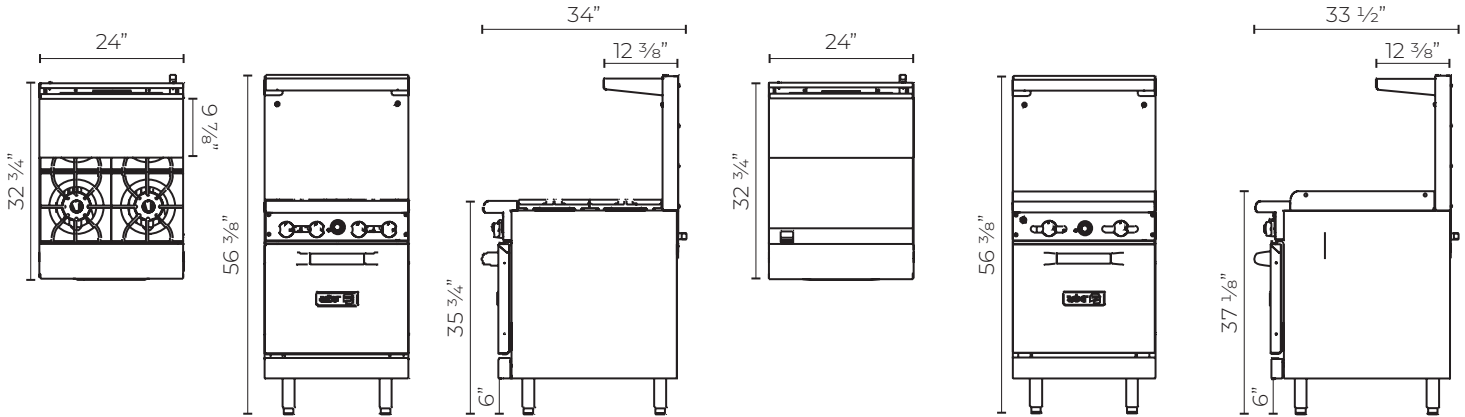

DATA	AER 4-24	AER G24-24-H
Gas Type	LPG or Nat. Gas (NG)	
Gas Connection	Gas line: 3/4" or larger	
Regulator	Included	
Gas Pressure	10.0" W.C. (LPG) or 5.0" W.C. (NG)	
Burner BTU	180.000	-
Griddle BTU	-	72.000
Oven BTU	30.000	
Total BTU	210.000	48.000
Shipping Weight (lbs)	335	405
DIMENSIONAL DATA		
Ext. Width Overall	24"	
Ext. Depth Overall	32 3/8"	
Ext. Height Overall ¹	56 3/8"	
OVEN		
# of Ovens	1	
Interior Length	19 1/4"	
Interior Depth	26 3/4"	
Interior Height	14 1/8"	

1. Height includes 6" legs and backsplash.

Standard Features

- Gas manifold.
- 6" adjustable legs.
- Independent pilot per burner.
- All units comes either Natural Gas (NG) or LPG Gas. Also includes conversion kits.

Open Burner

- Heavy Duty 12" x 12" cast iron top grates and pilot protection.
- Stainless Steel drip tray.

Griddles

- Cold-rolled steel plate 3/4" thick welded to the perimeter top of the truss.
- 4" grease trough channel.

Oven

- Stainless Steel interior with porcelain back door and bottom.
- Thermostatic controlled from 250 °F to 550 °F.
- Electronic spark ignition.
- Accepts full size sheet pans (18" x 26").

Options & Accessories

- 5" castors.
- Additional racks for oven.
- Extended overshelf for Salamander / Cheesemelter.
- Specify is above 2000 ft. elevation.

Warranty

- 1-year parts & labor.
- *RESIDENTIAL APPLICATIONS: Asber assumes no liability for parts or labor coverage for component failure, factory defect or any other damages for units installed in non-commercial foodservice or residential applications.

INSTALLATION REQUIREMENTS

- GAS PRESSURE:** 5.0" W.C. (NG) for natural gas or 10.0" W.C. (LPG) for propane gas. A pressure regulator sized for this unit is included, to be installed at time of connection.
- GAS CONNECTION:** Gas line must be 3/4" or larger, same if flexible connectors are used.
-
- VENTILATION:** An adequate ventilation system is required for commercial cooking equipment. Request more info @ National-Fire Protection Association, www.NFPA.org
- CLEARANCE:** 6" rear & sides for combustible. 0" rear & sides for non-combustible. In the lower part, a space of 4" for all models must be installed with legs of minimum 6".