

Gas Restaurant Economic Range with Oven

36" WIDE



All Stainless-Steel construction, interior and exterior front, and sides. To include **Stainless-Steel grate supports, burner support and pilot tubing**. The all Stainless-Steel construction is designed to last and perform in the most demanding kitchens.

Heavy gauge welded frame on 6" adjustable legs, Stainless-Steel back riser durable enough to hold your broiler without any additional supports. Comes standard with Stainless-Steel cantilever shelf with an optional extended shelf for broiler mounting.

For the safety and convenience of operators, our Asber ranges come standard with a 5" Stainless Steel bull nose landing ledge. All units are CSA and ANSI certified.

OPEN BURNER:

- **30.000 BTU** cast iron lift off burners.
- Heavy Duty 12" x 12" cast iron top grates and pilot protection.

OVEN:

- Stainless Steel interior with porcelain bottom.
- Removable Stainless-Steel door for easy cleaning.
- Thermostatic controlled from 250 °F to 550 °F, CSA and ANSI certified.
- Manual ignition.
- Standard with (1) stainless steel oven rack.
- **Accepts full size sheet pans (18" x 26").**



AER-6-36-E

OPTIONS & ACCESORIES

- 5" castors.
- Additional racks for oven.
- Extended overshelf for Salamander / Cheesemelter.
- Specify LPG or Nat. Gas.
- Specify is above 2000 ft. elevation.

MODEL	TOTAL BTU PER HOUR	Width	DIMENSIONS Depth	Height	SHIPPING WEIGHT (lbs)
AER-6-36-E	210.000	36"	33 1/2"	56 3/8"	375

1. Height includes 6" legs and backsplash. 2. Specifications are subject to change without prior notice.

Gas Restaurant Economic Range with Oven

36" WIDE

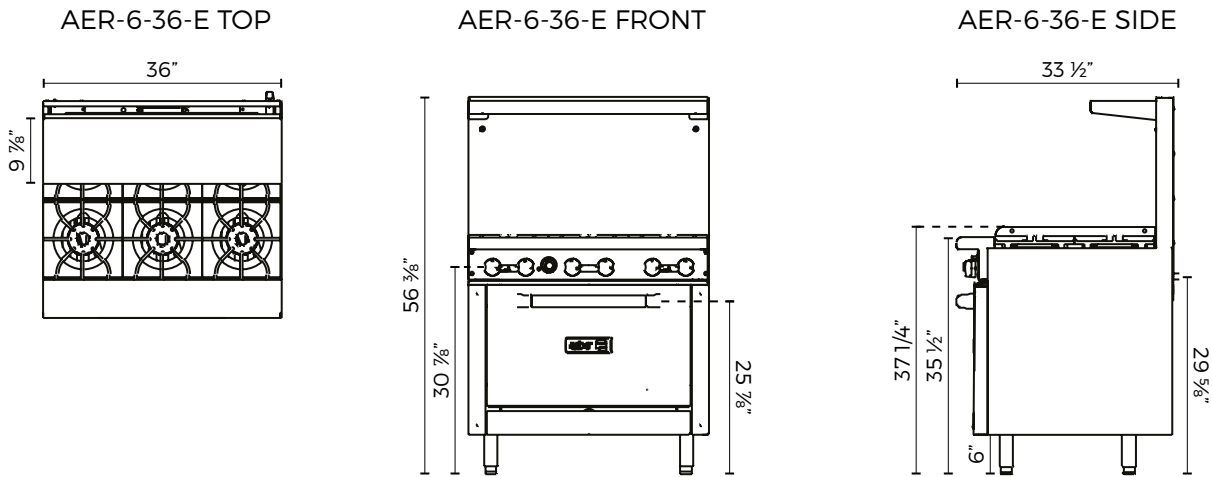

DATA		AER-6-36-E	
Gas Type	LPG or Nat. Gas (NG)		
Gas Connection	Gas line: 3/4" or larger		
Regulator	Included		
Gas Pressure	10.0" W.C. (LPG) or 5.0" W.C. (NG)		
Burner BTU	23,000	30,000	
Oven BTU	30,000		
Total BTU	168,000	210,000	
Shipping Weight (lbs)	375		
DIMENSIONAL DATA			
Ext. Width Overall	36"		
Ext. Depth Overall	33 1/2"		
Ext. Height Overall ¹	56 3/8"		
OVEN			
# of Ovens	1		
Interior Length	26 3/4"		
Interior Depth	22 7/8"		
Interior Height	14 1/8"		

1. Height includes 6" legs and backsplash.

Standard Features

- Gas manifold.
- 6" adjustable legs.
- Independent pilot per burner.

Open Burner

- Heavy Duty 12" x 12" cast iron top grates and pilot protection.
- Stainless Steel drip tray.

Oven

- Stainless Steel interior with porcelain back door and bottom.
- Thermostatic controlled from 250° F to 550° F, CSA and ANSI certified.
- Manual ignition.
- Accepts full size sheet pans (18" x 26").

Options & Accessories

- 5" castors.
- Additional racks for oven.
- Extended overshelf for Salamander / Cheesemelter.
- Must Specify LPG or Nat. Gas.
- Specify is above 2000 ft. elevation.

Warranty

- 1-year parts & labor.
- *RESIDENTIAL APPLICATIONS: Asber assumes no liability for parts or labor coverage for component failure, factory defect or any other damages for units installed in non-commercial foodservice or residential applications.

INSTALLATION REQUIREMENTS

- 1. GAS PRESSURE:** 5.0" W.C. (NG) for natural gas or 10.0" W.C. (LPG) for propane gas. A pressure regulator sized for this unit is included, to be installed at time of connection.
- 2. GAS CONNECTION:** Gas line must be 3/4" or larger, same if flexible connectors are used.
- 3. VENTILATION:** An adequate ventilation system is required for commercial cooking equipment. Request more info @ National-Fire Protection Association, www.NFPA.org
- 4. CLEARANCE:** 6" rear & sides for combustible. 0" rear & sides for non-combustible. In the lower part, a space of 4" for all models must be installed with legs of minimum 6".