

MAXIMIZER

Gas Pizza Ovens

MODEL CW41/CW61P



General Features:

- Quality Construction for long life
- Stainless Steel Front Standard
Stainless top & sides available (T430)
- Pizza Deck Standard
Large 42"x32"x7" compartments
1" pizza stones
- 4-Cell "Power-Pak" Burner System for better distribution of heat and better baking ability
- Thermostat
300°F - 650°F (149°C - 343°C)
- Space Saver
Only 50" wide
- Aluminized Interior Standard
- Easily Serviceable
Most controls can be replaced from the front of the unit
- Power
Gas - LP or NAT
- **Specific Features**
of the CW41/CW61P listed on back

Warranty:

- One year parts and labor



**GAS
FIRED**

Pizza Deck Standard

Hearth
Baffle
Burner

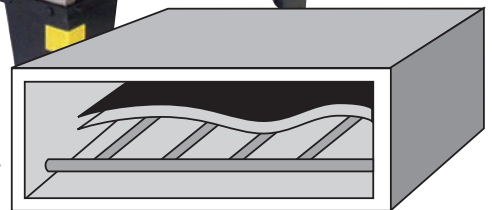

"Power-Pak" 4-Cell Burner System

MORE FOR LESS

More Cooking Space per Floor Space
More Cooking Capacity per Sales Dollar
More Performance per Gas Dollar



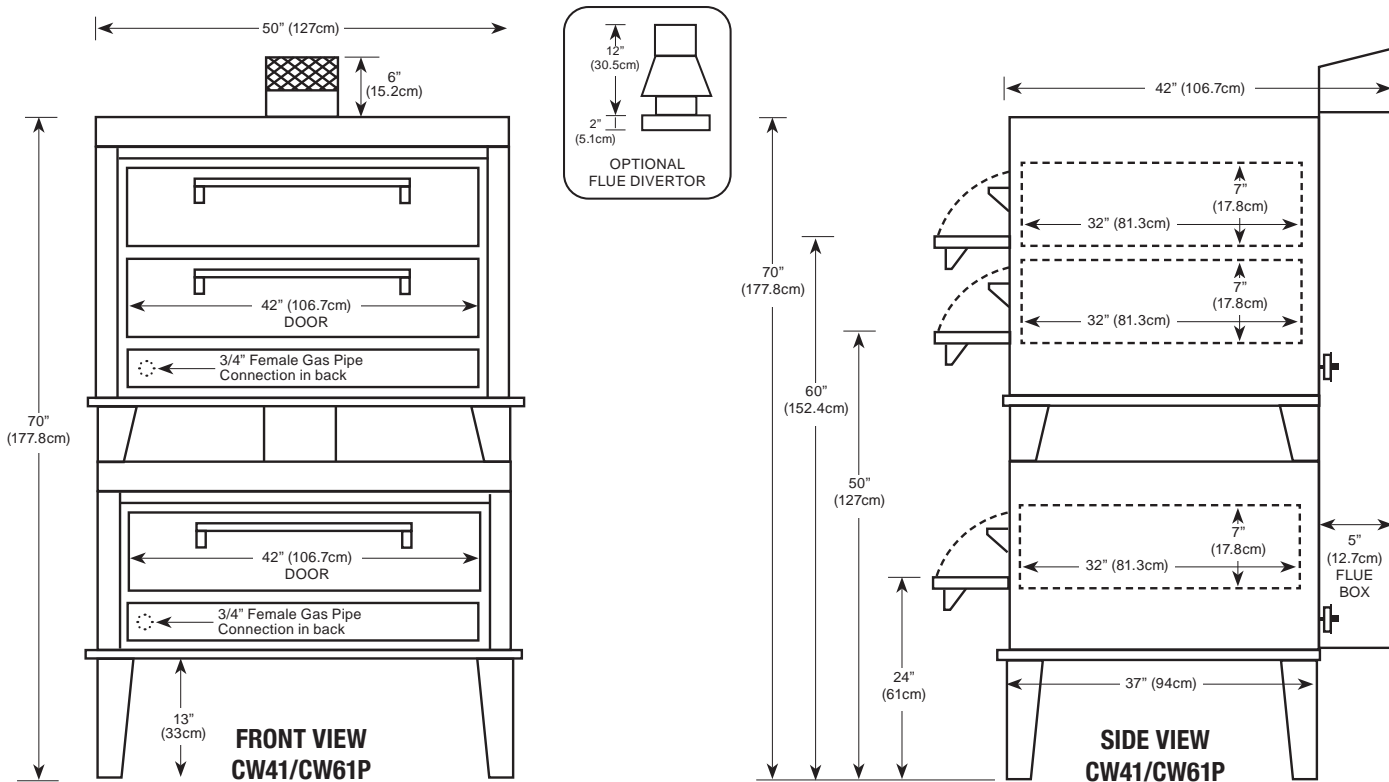

Floor space	50" (127cm) wide x 42" (106.7cm) deep* x 70" (177.8cm) high
Shelf size	42" (106.7cm) wide x 32" (81.3cm) deep x 7" (17.8cm) high (3)
Shipping weight	1475 lbs (669kg)
Capacity CW41P	Six 12" pizzas or four 16" pizzas
Capacity CW61P	Twelve 12" pizzas or eight 16" pizzas
Gas	Maximum 60,000 BTU input each (2)
Maximum opening required for installation: 31" * Handle adds 2.5"(6.4cm) to depth	

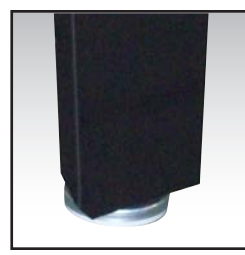

Adjustable Legs

Durable Construction

The CW41/CW61P is built with *prime 20-gauge cold-rolled top and sides* with a 14-gauge base. The *interior is made of Armco Type 1, 20-gauge aluminized steel*. The CW41/CW61P comes standard with stainless steel front, or optional all stainless steel finish. The stainless steel is made of high quality, 18-gauge 430 stainless; the door interior is 18 gauge stainless.

Energy Efficiency

The CW41/CW61P features our *new energy-saving "Power-Pak" 4-cell burner system* and our *unique baffle system*. These make our ovens highly efficient and eliminate hot spots. The *heavily insulated walls*, coupled with our *special vent system*, reduces heat loss and keep your gas dollars from going up the stack. The CW41/CW61P is powered by two (2) 60,000 highly efficient BTU burners which *increase its efficiency and recovery rate*.

Capacity

The CW41P deck size measures 42"x32"x7". Actual cooking capacity depends on the size of the pizza you are cooking. The CW41P will hold six (6) 12" pizzas or four (4) 16" pizzas. Cooking time will vary according to product, but will average between 8-10 minutes.

The CW61P deck size measures 42"x32"x7". Actual cooking capacity depends on the size of the pizza you are cooking. The CW61P will hold twelve (12) 12" pizzas or eight (8) 16" pizzas. Cooking time will vary according to product, but will average between 8-10 minutes.

Space Saver

Because the controls are under the door, the CW41/CW61P requires *less installation space* than our competition. This enables you to free up valuable kitchen and/or hood space. The actual width needed is mere 50" for three (3) *42"x32" decks*, almost a foot less than the competition.

Design Plus

The CW41/CW61P has the *controls in lower front for ease of operation and space savings*. This also places the controls in their own *air-conditioned area* so they are not affected by outside influences. In addition, the CW41/CW61P is *totally thermocoupled* and allows you to replace individual parts as opposed to throwing away the whole system.



Commercial and Industrial Ovens

P.O. Box 859 • Sandusky, Ohio 44870 • (419) 625-4514 • FAX 625-4597