

BakeMax America BATG Countertop Thermostatic Griddle

The BakeMax America BATG Series countertop thermostatic griddle is designed to provide the ultimate performance and durability. As with all of our heavy duty countertop equipment, they are built to the highest commercial standards to ensure years of trouble free service, featuring superior frame construction and stainless steel exterior for easy maintenance. Combine all of this and our affordable prices and you have the best value for your budget.



Model BATG24

Features:

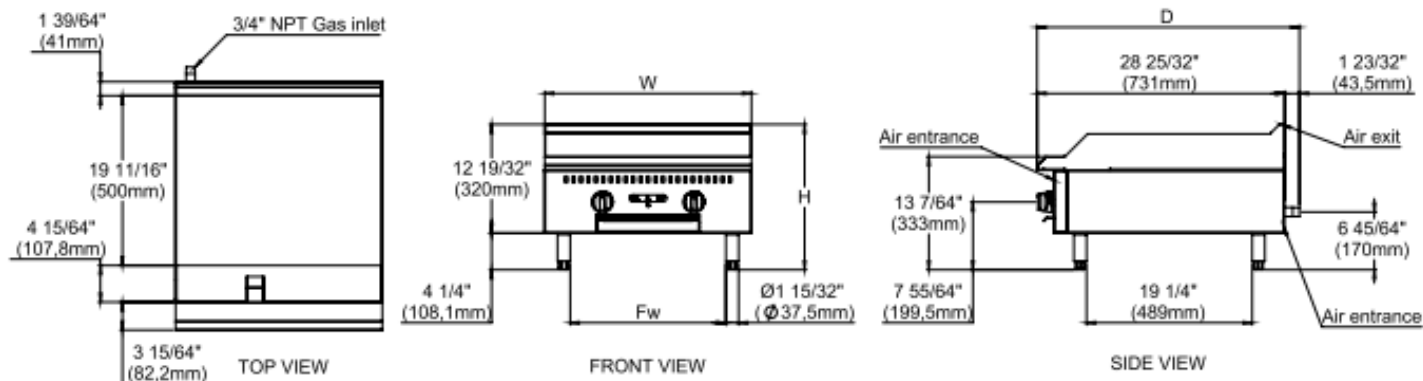

- Available in 15", 24", 36", 48" and 60".
- Stainless steel panel and sides
- Highly polished 3/4" steel griddle plate
- Easy light pilot at the side of each burner
- Independent controls for each burner
- Enameled burners, designed to achieve the best performance, providing a more uniform roast with low consumption.
- Fully welded griddle plate
- 200-575°F Energy-saving adjustable thermostat to control desired griddle plate surface temperature.
- Accessible pilots through front panel.
- Stainless steel splash guards around the griddles
- 4.4" enameled grease tray for easy clean up
- Individual control of each burner allowing greater autonomy in operation, with pilot flames always on.
- 3/4" rear gas connect
- Adjustable chromed stainless steel legs
- LP conversion kit included
- One-year limited parts and labor warranty



** Due to continuous product improvement, specifications are subject to change without notice.

BakeMax[®] / Titan Ventures International Inc.

Warehouses:

270 Baig Blvd, Suite A3, Moncton, NB, E1E1C8 
1605 Crescent Cr Carrollton, TX, Dallas, TX 75006 

Toll Free: 1-800-565-BAKE (2253)

Phone: 506-858-8990

Fax: 506- 859-6929

Email: Sales@BakeMax.com



America

www.BakeMax.com

Project: _____

Item: _____

Qty: _____ Date: _____

BakeMax America BATG Countertop Thermostatic Griddle

Technical Specifications & Drawings

Model	Width	Depth	Height	Burners	BTU NG	BTU LP
BATG15	15" (380mm)	31" (775mm)	17" (4428mm)	1	30,000	30,000
BATG24	24.2" (608mm)	31" (7775mm)	17" (428mm)	2	60,000	60,000
BATG36	36.2" (915mm)	31" (775mm)	17" (428mm)	3	90,000	90,000
BATG48	48.2" (1220mm)	31" (775mm)	17" (428mm)	4	120,000	120,000
BATG60	60.2" (1524mm)	31" (775mm)	17" (428mm)	5	150,000	150,000



***Warning:** The minimum supply pressure on this appliance must be set at 4 water column inches for natural gas and 10 water column for propane gas. Each unit has a 3/4" gas connect at the rear of the appliance.

Shipping Information

Model	Net Weight lbs/kg	Crated Weight lbs/kg	Crate Dimensions (D x W x H)
BATG15	108lbs/49kg	132lbs/60kg	34"X19"X20"
BATG24	163lbs/74kg	194lbs/88kg	34"X28"X20"
BATG36	227lbs/103kg	273lbs/124kg	34"X40"X20"
BATG48	315lbs/143kg	353lbs/160kg	34"X52"X20"
BATG60	360lbs/163kg	430lbs/195kg	34"X64"X20"

BakeMax ® / Titan Ventures International Inc.

Warehouses:

270 Baig Blvd, Suite A3, Moncton, NB, E1E1C8 
1605 Crescent Cr Carrollton, TX, Dallas, TX 75006 

Toll Free: 1-800-565-BAKE (2253)

Phone: 506-858-8990

Fax: 506- 859-6929

Email: Sales@BakeMax.com